

Hülsenverschraubungen

Gewicht Weight Approx. ≈ kg	FÜR SCHLAUCHGRÖSSE For Hose Size			GEWINDE ART + GRÖSSE Thread Type + Size G	BESTELL- NUMMER Part Number Type	
	ID mm	ID in.	OD mm			
0,12	13	1/2"	22	R 1/2" (BSP)	M 13 - 1/2"	Mutterverschraubungen mit Schraubhülsen - Einband, geeignet zur Selbstmontage. Entsprechen DIN EN 14424 und Bundeswehnorm VG 95951. Nenndruck bis 25 bar. - Chemische Beständigkeit siehe Seite 250.
0,13				R 3/4" (BSP)	M 13 - 3/4"	
0,14				R 1" (BSP)	M 13 - 1"	
0,13	16	5/8"	26	R 5/8" (BSP)	M 16 - 5/8"	Hose fittings (ferrule type) with union nut (female thread), suitable for self-assembly. Working pressure up to 25 bar. Meet EN 14424. Chemical resistance chart see page 250.
0,14				R 3/4" (BSP)	M 16 - 3/4"	
0,15				R 1" (BSP)	M 16 - 1"	
0,17				M 30 x 1,5 links left	M 16 - 30 LPG	
0,14	19	3/4"	27	R 3/4" (BSP)	M 19 - 3/4" LC	Schlauchstutzen, Hülsen und Mutter aus Messing. Dichtung Polyurethan
0,17				R 1" (BSP)	M 19 - 1" LC	
0,17	19	3/4"	31	R 3/4" (BSP)	M 19 - 3/4"	Type M Hose tail, union nut and ferrule of brass. Captive seal polyurethane
0,18				R 1" (BSP)	M 19 - 1"	
0,20				M 30 x 1,5 links left	M 19 - 30 LPG	
0,24				R 1 1/4" (BSP)	M 19 - 1 1/4"	
0,28	25	1"	34	R 1" (BSP)	M 25 - 1" LC	Type M - cr Hose tail, union nut and ferrule of brass, chrome plated. Captive seal polyurethane
0,23				R 1" (BSP)	M 25 - 1"	
0,27	25	1"	37	R 1 1/4" (BSP)	M 25 - 1 1/4"	Type M - SS Schlauchstutzen aus 1.4571. Mutter aus 1.4571(1.4408). Hülsen aus Messing verchromt. Dichtung PTFE
0,29				R 1 1/2" (BSP)	(M 25 - 1 1/2")	
0,35	32	1 1/4"	44	R 1 1/4" (BSP)	(M 32 - 1 1/4")	Type M - NR Werksmontierte Hülsen-Mutterverschraubungen, nicht demontierbar. Anschlussmaße entsprechend DIN EN 14424. Nenndruck 25 bar. Lieferung nur als komplette Schlauchleitung, da Spezialmaschine zur Montage erforderlich.
0,42				R 1 1/2" (BSP)	(M 32 - 1 1/2")	
0,12	13	1/2"	22	R 1/2" (BSP)	M 13 - 1/2" cr	Ausführung wie Type M, jedoch Mutter und Hülsen verchromt. Dichtung Polyurethan
0,13				R 3/4" (BSP)	M 13 - 3/4" cr	
0,14	16	5/8"	26	R 3/4" (BSP)	M 16 - 3/4" cr	Type M - cr Hose tail, union nut and ferrule of brass, chrome plated. Captive seal polyurethane
0,15				R 1" (BSP)	M 16 - 1" cr	
0,17	19	3/4"	31	R 3/4" (BSP)	M 19 - 3/4" cr	Type M - SS Schlauchstutzen aus 1.4571. Mutter aus 1.4571(1.4408). Hülsen aus Messing verchromt. Dichtung PTFE
0,18				R 1" (BSP)	M 19 - 1" cr	
0,20	21	7/8"	31	R 1" (BSP)	M 21 - 1" cr	Type M - NR Schlauchstutzen, Hülsen und Mutter Messing. Dichtung Polyurethan
0,23				R 1" (BSP)	M 25 - 1" cr	
0,27	25	1"	37	R 1 1/4" (BSP)	M 25 - 1 1/4" cr	Type M - NR Hose tail, union nut and ferrule hot stamped brass. Captive seal polyurethane
0,27				R 1 1/4" (BSP)	M 25 - 1 1/4" SS	
0,12	13	1/2"	22	R 1/2" (BSP)	M 13 - 1/2" SS	Type M - SS Schlauchstutzen aus 1.4571. Mutter aus 1.4571(1.4408). Hülsen aus Messing verchromt. Dichtung PTFE
0,13				R 3/4" (BSP)	M 13 - 3/4" SS	
0,13	16	5/8"	26	R 3/4" (BSP)	M 16 - 3/4" SS	Type M - NR Werksmontierte Hülsen-Mutterverschraubungen, nicht demontierbar. Anschlussmaße entsprechend DIN EN 14424. Nenndruck 25 bar. Lieferung nur als komplette Schlauchleitung, da Spezialmaschine zur Montage erforderlich.
0,14				R 1" (BSP)	M 16 - 1" SS	
0,17	19	3/4"	31	R 3/4" (BSP)	M 19 - 3/4" SS	Type M - NR Schlauchstutzen, Hülsen und Mutter Messing. Dichtung Polyurethan
0,18				R 1" (BSP)	M 19 - 1" SS	
0,23	25	1"	37	R 1" (BSP)	M 25 - 1" SS	Type M - NR Hose tail, union nut and ferrule hot stamped brass. Captive seal polyurethane
0,27				R 1 1/4" (BSP)	M 25 - 1 1/4" SS	
0,15	16	5/8"	26	R 3/4" (BSP)	M 16 - 3/4" NR	Type M - NR Werksmontierte Hülsen-Mutterverschraubungen, nicht demontierbar. Anschlussmaße entsprechend DIN EN 14424. Nenndruck 25 bar. Lieferung nur als komplette Schlauchleitung, da Spezialmaschine zur Montage erforderlich.
0,16				R 1" (BSP)	M 16 - 1" NR	
0,09	19	3/4"	31	R 1" (BSP)	M 19 - 1" NR *)	Type M - NR Schlauchstutzen, Hülsen und Mutter Messing. Dichtung Polyurethan
0,09				R 1" (BSP)	M 21 - 1" NR	
0,23	25	1"	37	R 1" (BSP)	M 25 - 1" NR	Type M - NR Hose tail, union nut and ferrule hot stamped brass. Captive seal polyurethane
0,15				R 3/4" (BSP)	M 16 - 3/4" NR cr	
0,16	16	5/8"	26	R 1" (BSP)	M 16 - 1" NR cr	Type M - NR Werksmontierte Hülsen-Mutterverschraubungen, nicht demontierbar. Anschlussmaße entsprechend DIN EN 14424. Nenndruck 25 bar. Lieferung nur als komplette Schlauchleitung, da Spezialmaschine zur Montage erforderlich.
0,09				R 3/4" (BSP)	M 19 - 1" NR cr *)	
0,09	21	7/8"	31	R 1" (BSP)	M 21 - 1" NR cr *)	Type M - NR Hose tail, union nut and ferrule hot stamped brass. Captive seal polyurethane
0,23				R 1" (BSP)	M 25 - 1" NR cr	

cr = Mutter + Hülsen verchromt

Union nut + ferrule chrome plated

Hülsen und Stutzen aus Aluminium, nicht verchromt

*) = Ferrule and hose tail of aluminium, not chrome plated

Hülsenverschraubungen

Gewicht Weight Approx. ≈ kg	FÜR SCHLAUCHGRÖSSE For Hose Size			GEWINDE ART + GRÖSSE Thread Type + Size G	BESTELL- NUMMER Part Number Type	
	ID mm	ID in.	OD mm			
0,11	13	1/2"	22	R 1/2" (BSP)	V 13 - 1/2"	Vaternverschraubungen mit Schraubhülsen - Einband, geeignet zur Selbstmontage. Entsprechen DIN EN 14424 und Bundeswehnorm VG 95951. Nenndruck bis 25 bar. - Chemische Beständigkeit siehe Seite 250. Hose fittings (ferrule type) with male thread, suitable for self-assembly. Working pressure up to 25 bar. Meet EN 14424. Chemical resistance chart see page 250.
0,12				1/2" NPT (API)	V 13 - 1/2" NPT	
0,15	16	5/8"	26	R 3/4" (BSP)	V 16 - 3/4"	
0,16				R 3/4" DIN 2999 (BSPT)	V 16 - 3/4" BSPT	
0,16				3/4" NPT (API)	V 16 - 3/4" NPT	
0,17	19	3/4"	27	R 1" (BSP)	V 16 - 1"	
0,17				R 1" DIN 2999 (BSPT)	V 16 - 1" BSPT	
0,14				R 3/4" (BSP)	V 19 - 3/4" LC	
0,17				R 1" (BSP)	V 19 - 1" LC	
0,17	19	3/4"	31	R 3/4" (BSP)	V 19 - 3/4"	
0,17				R 3/4" DIN 2999 (BSPT)	V 19 - 3/4" BSPT	
0,17				3/4" NPT (API)	V 19 - 3/4" NPT	
0,20				R 1" (BSP)	V 19 - 1"	
0,20				R 1" DIN 2999 (BSPT)	V 19 - 1" BSPT	
0,21				R 1" (BSP)	V 21 - 1"	
0,22	25	1"	34	R 1" (BSP)	V 25 - 1" LC	
0,23				1" NPT (API)	V 25 - 1" NPT LC	
0,24	25	1"	37	R 1" (BSP)	V 25 - 1"	
0,25				R 1" DIN 2999 (BSPT)	V 25 - 1" BSPT	
0,25				1" NPT (API)	V 25 - 1" NPT	
0,15				R 3/4" (BSP)	V 16 - 3/4" cr	
0,16	16	5/8"	26	R 3/4" DIN 2999 (BSPT)	V 16 - 3/4" BSPT cr	
0,16				3/4" NPT (API)	V 16 - 3/4" NPT cr	
0,17				R 1" (BSP)	V 16 - 1" cr	
0,17	19	3/4"	31	R 1" DIN 2999 (BSPT)	V 16 - 1" BSPT cr	
0,17				R 3/4" (BSP)	V 19 - 3/4" cr	
0,17				R 3/4" DIN 2999 (BSPT)	V 19 - 3/4" BSPT cr	
0,17				3/4" NPT (API)	V 19 - 3/4" NPT cr	
0,20				R 1" (BSP)	V 19 - 1" cr	
0,21				R 1" DIN 2999 (BSPT)	V 19 - 1" BSPT cr	
0,21	21	7/8"	31	R 1" (BSP)	V 21 - 1" cr	
0,24				R 1" (BSP)	V 25 - 1" cr	
0,25	25	1"	37	R 1" DIN 2999 (BSPT)	V 25 - 1" BSPT cr	
0,25				1" NPT (API)	V 25 - 1" NPT cr	
0,11	13	1/2"	22	R 1/2" (BSP)	V 13 - 1/2" SS	Schlauchstutzen aus 1.4571. Hülse aus Pressmessing blank verchromt Schlauchstutzen und Hülse: Pressmessing blank verchromt Type V - cr Hose tail and ferrule of hot stamped brass, chrome plated
0,12				1/2" NPT (API)	V 13 - 1/2" NPT SS	
0,14	16	5/8"	26	R 5/8" (BSP)	V 16 - 5/8" SS	
0,15				R 3/4" (BSP)	V 16 - 3/4" SS	
0,16				3/4" NPT (API)	V 16 - 3/4" NPT SS	
0,17	19	3/4"	31	R 3/4" (BSP)	V 19 - 3/4" SS	
0,17				3/4" NPT (API)	V 19 - 3/4" NPT SS	
0,20				R 1" (BSP)	V 19 - 1" SS	
0,24				R 1" (BSP)	V 25 - 1" SS	
0,25	25	1"	37	1" NPT (API)	V 25 - 1" NPT SS	
0,27				R 1 1/4" (BSP)	V 25 - 1 1/4" NPT SS	
0,15	16	5/8"	26	R 3/4" (BSP)	V 16 - 3/4" NR	Werksmontierte Hülsen - Vaternverschraubungen, nicht demontierbar. Schlauchstutzen und Hülse Pressmessing (cr: verchromt) Type V - NR Hose tail and ferrule hot stamped brass (cr: chrome plated). Factory assembled hose fittings (ferrule type), non-reattachable .
0,16				R 3/4" (BSPT)	V 16 - 3/4" BSPT NR	
0,17				R 1" (BSP)	V 16 - 1" NR	
0,24	25	1"	37	R 1" (BSP)	V 25 - 1" NR	
0,15				R 3/4" (BSP)	V 16 - 3/4" NR cr	
0,16				R 3/4" (BSPT)	V 16 - 3/4" BSPT NR cr	
0,17	16	5/8"	26	R 1" (BSP)	V 16 - 1" NR cr	
0,24				R 1" (BSP)	V 25 - 1" NR cr	

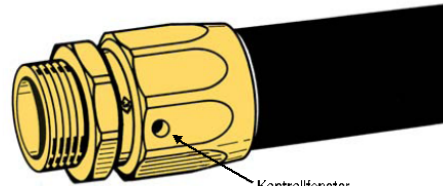

Kontrollfenster
control opening

Schlauchstutzen und Hülse: Pressmessing blank gebeizt

Type V

Hose tail and ferrule of hot stamped brass.

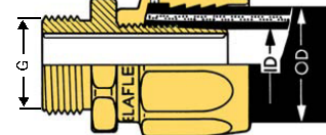

Schlauchstutzen und Hülse: Pressmessing blank verchromt

Type V - cr

Hose tail and ferrule of hot stamped brass, chrome plated

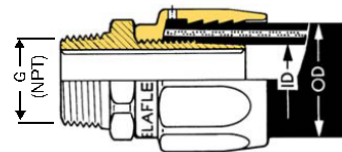

Schlauchstutzen aus 1.4571. Hülse aus Pressmessing blank verchromt

Type V - SS

Hose tail with male thread of stainless steel. Ferrule of hot stamped brass, chrome plated.

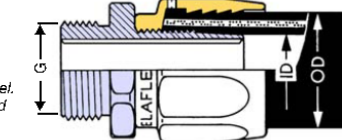

Hülensverschraubungen, Sonderausführungen + Zubehör

1

Einfache Mutterschraubung aus Messing mit Dichtung für Leichtzapf- und Faßpumpenschläuche

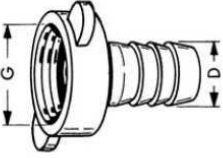

Simple hose fitting with union nut of brass with seal. For barrel pump- and light weight pump hoses

D mm	G	Bestellnummer Part Number
13	R 3/4"	M 13 - 3/4" LSB
16	R 3/4"	M 16 - 3/4" LSB
19	R 1"	M 19 - 1" LSB
25	R 1 1/4"	M 25 - 1 1/4" LSB

2

Preiswerter Leichtschlauchbinder aus Stahl, galv. verzinkt, für Fasspumpenschläuche und Leichtzapfschläuche

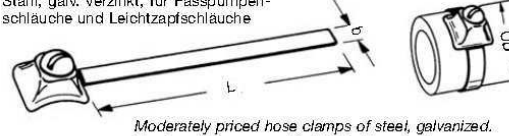

Moderately priced hose clamps of steel, galvanized. For barrel pump - and light weight pump hoses.

für Schlauch for Hose Size	OD	L	b	Bestellnummer Part Number
15 - 30 mm		100	5	LSB 100
30 - 45 mm		150	7	LSB 150

3

Ersatzdichtungen für Mutterschraubungen

Spare Seals for hose fittings with union nut

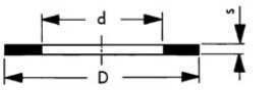

für for	D mm	d mm	s mm	Werkstoff Material	Bestellnummer Part Number
G 1/2"	20	13	2	Polyurethan/Polyurethane	VD 20/13
				PTFE	TD 20/13
W 21,8 x 1/14" links	22	12	2	Polyurethan/Polyurethane	VD 22/12
G 5/8"	23	16	2	Polyurethan/Polyurethane	VD 23/16
				Polyurethan/Polyurethane	VD 26/19
				Thermopac	HBD 26/19
				PTFE	TD 26/19
ZV 201-4 M 30 x 1,5	30	21	2	Polyurethan/Polyurethane	VD 30/21
				Polyurethan/Polyurethane	VD 33/24
				Thermopac	HBD 33/24
				PTFE	TD 33/24
				Polyurethan/Polyurethane	VD 42/28
				Thermopac	HBD 42/28
				PTFE	TD 42/28

4

Spezialdichtung NYD aus Polyamid, für Vaterverschraubungen mit Gewindehinterdrehung. Wird verwendet, wenn bei flachdichtenden Gewindeverbindungen auf der Mutterseite keine sichere Abdichtung erreicht werden kann.

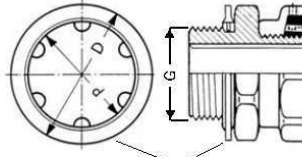

D	d	G	Bestellnummer Part Number
34,8	28,5	3/4"	NYD 3/4"
42,5	35,0	1"	NYD 1"

Type NYD

Special washer NYD of polyamide, for male threaded fittings with recess. Can be used, if no safe tightness can be achieved on the female side with flat sealing thread connections. Not suitable for NPT thread.

5

Sonderausführung für Schlauch LPG 10 für Flüssiggaswaagen, mit Schraubhülse einband, ganz aus Messing, mit Mutter W 21,8 x 1/14" links mit Vulkollan-Dichtung VD 22/12



LPG 10 - DIN 4815 - PN 25

Special type for LP-gas hose LPG 10, with re-usable fitting (female type) of brass, with union nut with left-hand thread W 21,8 x 1/14" left and captive seal of polyurethane

6

Widerhaken zum Herausziehen alter Presskonusstützen ZV 201 / 203

Barb for disassembling of old "presscone" hose fittings ZV 201 / 203

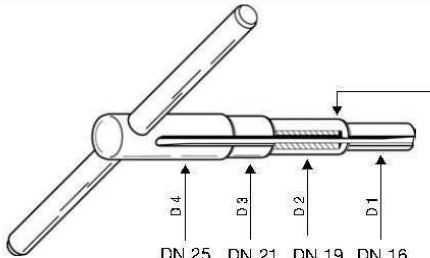

DN 25 DN 21 DN 19 DN 16

Steckschlüssel EW 15 / 25

Zur Montage von wiederverwendbaren Hülenschlauchverschraubungen DN 16 - 25. Aus Stahl, rostgeschützt.

D 1	D 2	D 3	D 4	Bestellnummer Part Number
f. DN 16	f. DN 19	f. DN 21	f. DN 25	EW - 15/25

Box Spanner EW 15 / 25

For assembly of reusable hose fittings (female type) DN 16 - DN 25. Of steel, zinc plated and chromated

7

Doppelmaulschlüssel

aus Werkzeugstahl, für ZVA-Zapfventile und ELAFLEX - Schlauchverschraubungen

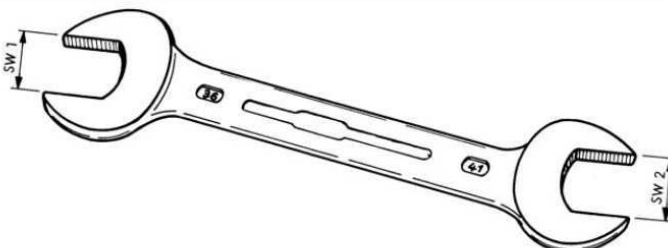

SW 1	SW 2	Bestellnummer Part Number
36	41	EW - M 36/41
41	46	EW - M 41/46

Double Head Wrench

of carbon steel. For "ZVA" nozzles and hose couplings

Einbindung von Hülsearmaturen

